

**SONY**<sup>®</sup>

Scale Unit

# **SH11 Series**

Read all the instructions in the manual carefully before use and strictly follow them.  
Keep the manual for future references.

Instruction Manual

## [For the customers in U. S. A.]

### WARNING

This equipment has been tested and found to comply with the limits for a Class A digital device, pursuant to Part 15 of the FCC Rules. These limits are designed to provide reasonable protection against harmful interference when the equipment is operated in a commercial environment. This equipment generates, uses, and can radiate radio frequency energy and, if not installed and used in accordance with the instruction manual, may cause harmful interference to radio communications. Operation of this equipment in a residential area is likely to cause harmful interference in which case the user will be required to correct the interference at his own expense. You are cautioned that any changes or modifications not expressly approved in this manual could void your authority to operate this equipment.

#### ■ Precautions on use

When using Sony Manufacturing Systems Corporation products, observe the following general precautions along with those given specifically in this manual to ensure proper use of the products.

- Before and during operations, be sure to check that our products function properly.
- Provide adequate safety measures to prevent damages in case our products should develop malfunctions.
- Use outside indicated specifications or purposes and modification of our products will void any warranty of the functions and performance as specified of our products.
- When using our products in combination with other equipment, the functions and performances as noted in this manual may not be attained, depending on operating and environmental conditions.
- Absolutely do not disassemble parts other than those specified, as this may cause malfunctions.
- Sony Manufacturing Systems Corporation reserves the right to change specifications and functions without notice.

## [ For EU and EFTA countries ]

### CE Notice

Making by the symbol CE indicates compliance of the EMC directive of the European Community. Such marking is indicative meets or exceeds the following technical standards.

#### EN 55 011 Group 1 Class A / 91 :

"Limits and methods of measurement of electromagnetic disturbance characteristics of industrial, scientific and medical (ISM) radio-frequency equipment"

#### EN 50 082-2 / 95:

"Electromagnetic compatibility - Generic immunity standard Part 2 : Industrial environment"

### 警告

本装置を機械指令 (EN 60 204-1) の適合を受ける機器にご使用の場合は、その規格に適合するように方策を講じてから、ご使用ください。

### Warning

When using this device with equipment governed by Machine Directives EN 60 204-1, measures should be taken to ensure conformance with those directives.

### Warnung

Wenn dieses Gerät mit Ausrüstungsteilen verwendet wird, die von den Maschinenrichtlinien EN 60 204-1 geregelt werden, müssen Maßnahmen ergriffen werden, um eine Übereinstimmung mit diesen Normen zu gewährleisten.

# Safety Precautions

Sony Manufacturing Systems Corporation products are designed in full consideration of safety. However, improper handling during operation or installation is dangerous and may lead to fire, electric shock or other accidents resulting in serious injury or death. In addition, these actions may also worsen machine performance.

Therefore, be sure to observe the following safety precautions in order to prevent these types of accidents, and to read these “Safety Precautions” before operating, installing, maintaining, inspecting, repairing or otherwise working on this unit.

## Warning indication meanings

The following indications are used throughout this manual, and their contents should be understood before reading the text.

### **Warning**

Failure to observe these precautions may lead to fire, electric shock or other accidents resulting in serious injury or death.

### **Caution**

Failure to observe these precautions may lead to electric shock or other accidents resulting in injury or damage to surrounding objects.

### **Note**

This indicates precautions which should be observed to ensure proper handling of the equipment.

## **Warning**



- Do not use this unit with voltages other than the specified supply voltage as this may result in fire or electric shock.



- Do not perform installation work with wet hands as this may result in electric shock.
- Do not disassemble or modify the unit as this may result in injury or damage the internal circuits.

## **Caution**



- Be sure to check the machine and device conditions to ensure work safety before working on the machine.

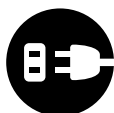

- Be sure to cut off the power supply, air and other sources of drive power before working on the machine. Failure to do so may result in fire or accidents.



- When turning on the power supply, etc. to operate the machine, take care not to catch your fingers in peripheral machines and devices.

# Handling Precautions

---

## Installation precautions

When installing this unit, care should be given to the following points to prevent noise and electromagnetic wave interference from other equipment.

1. Do not pass lead and connection cables through the same ducts as power lines.
  2. Be sure to install the unit at least 0.5 m or more away from high voltage or large current sources or high-power relays.
  3. Absolutely do not bring the unit near magnets or sources of electromagnetic waves.
- 

## Installation place precautions

1. The scale unit should be used within an ambient temperature range of 0 to 45°C (113°F). Avoid use in places exposed to direct sunlight or hot winds or near heating equipment.
2. Avoid use in places subject to strong vibrations or impacts.
3. If there is the chance that the scale unit may come into contact with cut or measured objects, tools or jigs, be sure to protect the unit with a sufficiently strong cover.

# Contents

<b>Introduction</b> .....	<b>1</b>
Introduction .....	1
Checklist for Unpacking and Accessories .....	2
<b>Chapter 1 Overview</b> .....	<b>1-1</b>
1-1. Special Features .....	1-1
1-2. Part Names .....	1-2
1-3. System Configuration .....	1-3
<b>Chapter 2 Design and Installation</b> .....	<b>2-1</b>
2-1. External Dimensions .....	2-1
2-2. Installation Design .....	2-3
2-3. Installation Procedure .....	2-6
2-3-1. Installing the Scale Unit .....	2-6
2-3-2. Securing the Scanning Unit to the Mounting Bracket .....	2-8
2-3-3. Removing the Slider Holders .....	2-9
2-3-4. Cable Management .....	2-10
2-3-5. Precautions when the Scanning Unit is Connected to a Movable Component .....	2-11
2-3-6. Connection Example (Reference) .....	2-12
2-4. Managing the Operating Environment .....	2-13
2-5. Air Purge .....	2-14
<b>Chapter 3 Maintenance</b> .....	<b>3-1</b>
3-1. Start-up Inspection .....	3-1
3-2. Regular Inspections .....	3-1
<b>Chapter 4 Specifications</b> .....	<b>4-1</b>
4-1. General Specifications and Performance Specifications .....	4-1
4-2. Resolution and Response Speeds .....	4-2
4-3. Electrical Characteristics .....	4-3
4-3. Cable Specifications .....	4-4
<b>Chapter 5 Appendix</b> .....	<b>5-1</b>
5-1. Model Summary .....	5-1



# Introduction

## Introduction

Thank you for purchasing this SH11 scale.

Please note that improper usage and handling may not only prevent this unit from functioning to its fullest potential, but may also cause unexpected breakdowns or shorten the life of the unit.

Be sure to read this instruction manual carefully and take the greatest care in handling the unit.

The precautions listed below are important for the proper handling of this product. Therefore, be sure to comply with the items and explanations in this instruction manual that advise caution.

In this instruction manual, we have endeavored to state wherever possible, the individual specifications and functions, and their interrelationships. Please assume that aspects not covered in this manual are not permitted.

Every care has been taken to make this manual as comprehensive as possible, but if you have any unanswered questions, do not hesitate to contact our sales center.

## Checklist for Unpacking and Accessories

### After unpacking this product, confirm the following:

- Is the article the one you ordered?
- Has any damage occurred during transit?

### Check to make sure the following accessories are included:

- Standard Accessories

Accessory name	Dimensions	Number	Application
Certificate of inspection		1	
Installation manual		1	
Hexagonal socket head cap screw	M4×22	4	For installing the scale
Cable clamp		2	For securing the head cable
Pan-head machine screw	M4×10	2	For securing the head cable
Pan-head machine screw 3P	M4×28	2	For securing the detector unit
Support bracket components		(See table below)	

- Support bracket components (The number of articles may differ depending on the scale model.)

Scale model	Support bracket		Hexagonal socket head cap screws, etc. for securing		
	A	B	M3×6	M4×18	Washers
SH-11-007□□□2 to -047□□□2	—	—	—	—	—
SH-11-052□□□2 to -092□□□3	1	1	2	1	1
SH-11-102□□□3 to -124□□□3	2	2	4	2	2



# Chapter 1 Overview

## 1-1. Special Features

The SH11 Series uses a high precision interpolation circuit to achieve an insertion error of 0.1  $\mu\text{m}$  or less within a scale engraving pitch of 16  $\mu\text{m}$ .

The output signal is a 5 V line driver, so it can be connected directly to a numerical controller to provide position feedback.

Installation is easy for this unit-type scale. For scales with a measuring length of 520 mm (20.47 in) or more, use standard accessory support bracket A or B to increase the rigidity at the intermediate position.

---

### Wide Variation

Twenty measuring lengths are available in the range of 70 to 1,240 mm (2.76 to 48.82 in).

Choose the optimum scale length to match the required stroke.

---

### High Precision

The scale precision is as follows.

- Measuring length 70 to 620:  $\pm 2 \mu\text{m}$
- Measuring length 670 to 1240:  $\pm 3 \mu\text{m}$

---

### Excellent Resistance to Working Environment

The detector component employs a large-area optical exchange device using Moiré interference fringes. Employing our unique stable Moiré detection system, the effects of dust can be minimized and reading errors reduced.

---

### Durable Construction

The detector component employs sturdy, precision die-cast aluminum, making it possible to obtain stable Moiré fringes. A bearing guide system enables maintenance of ideal traveling conditions.

---

### Minimum Wiring

Position detection signals are provided for only the following three pairs.

- Position signal ..... A phase,  $\bar{A}$  phase, B phase,  $\bar{B}$  phase
- Zero point signal ..... Z phase,  $\bar{Z}$  phase

Each of these employs the noise-resistant line-driver method.

---

### Simple Maintenance

The detector component is designed to be replaceable, so if a problem occurs, the scanning unit can be speedily replaced and normal operation resumed.

## 1-2. Part Names

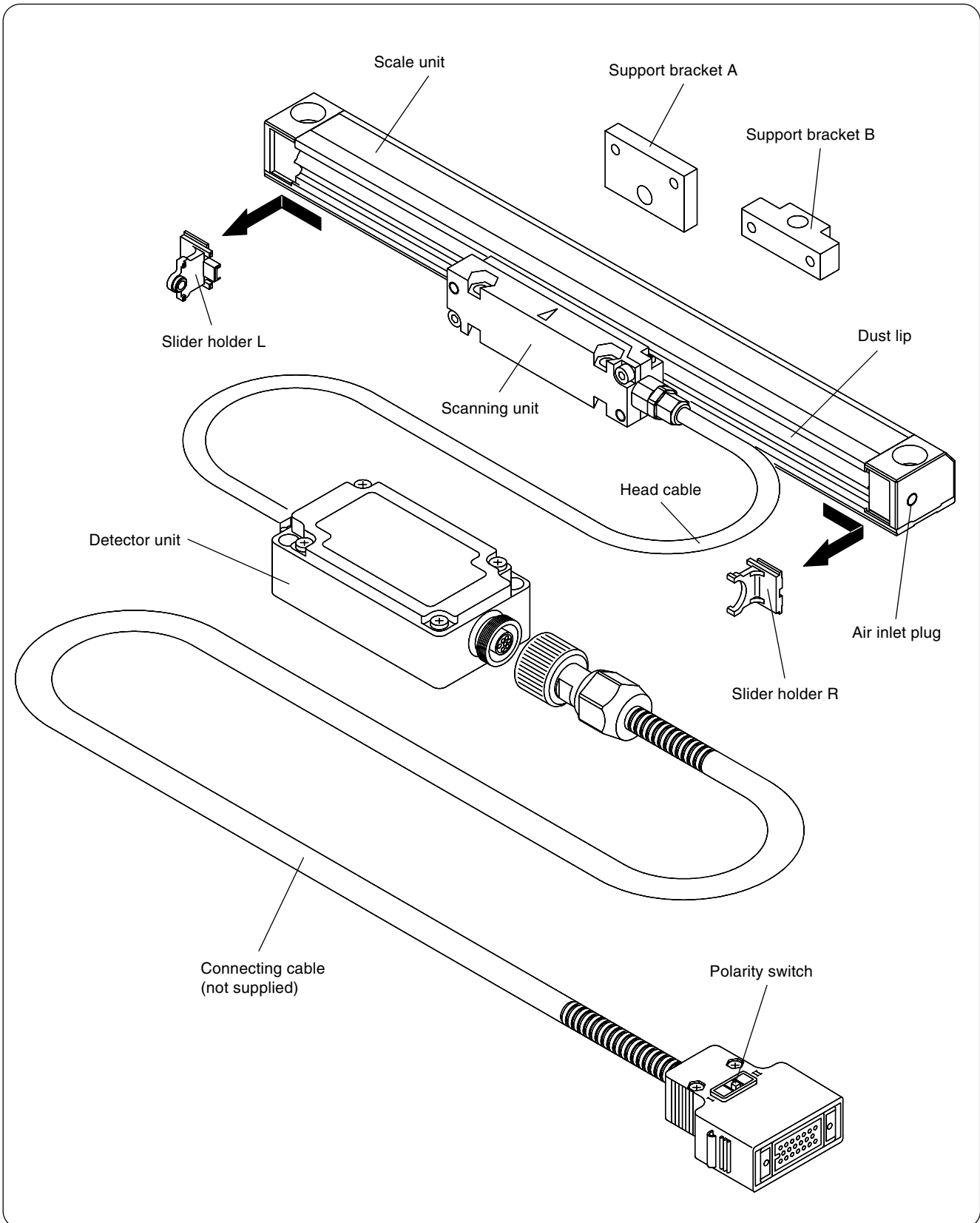

### 1-3. System Configuration

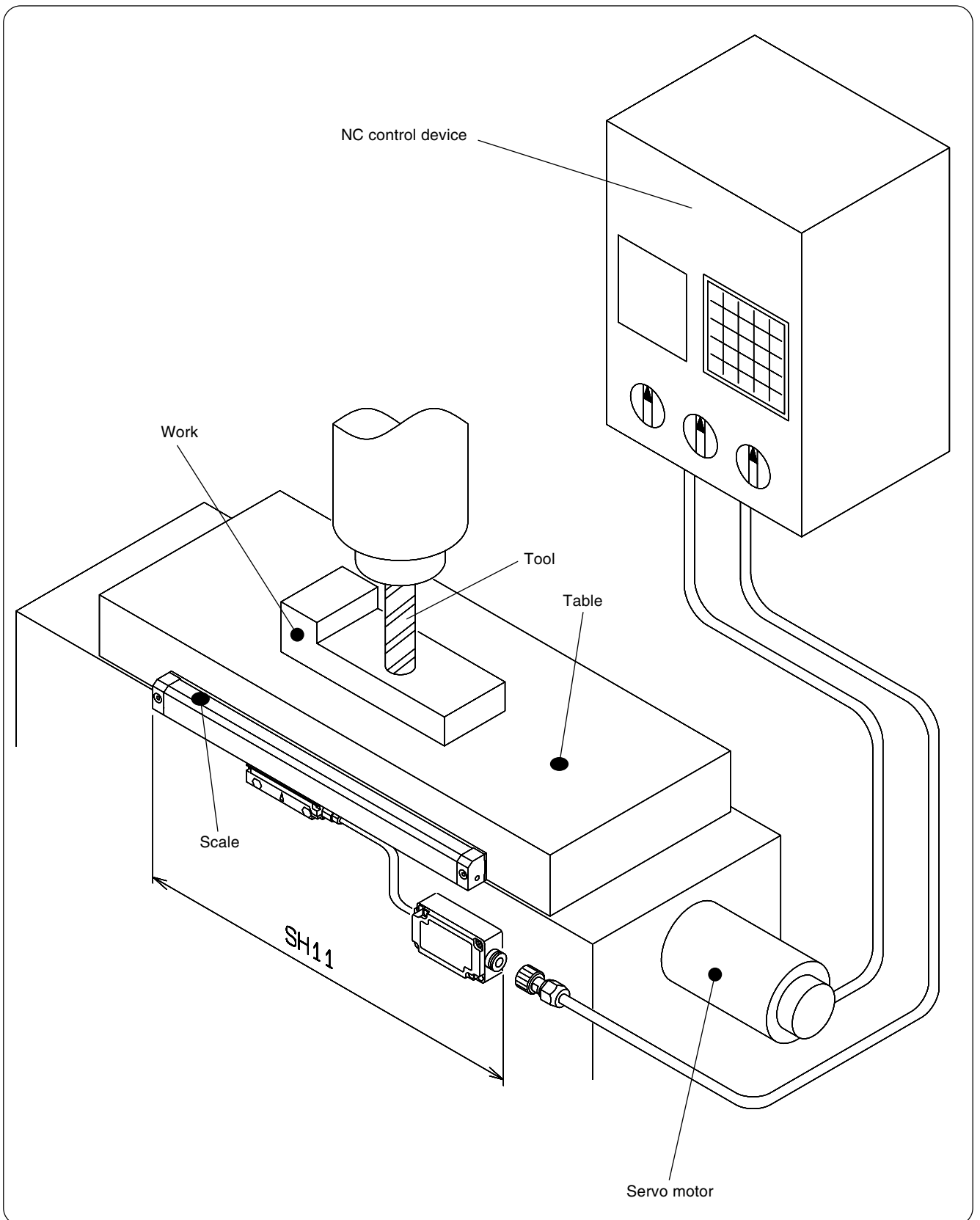



# Chapter 2 Design and Installation

## 2-1. External Dimensions

### External dimensions of scale unit

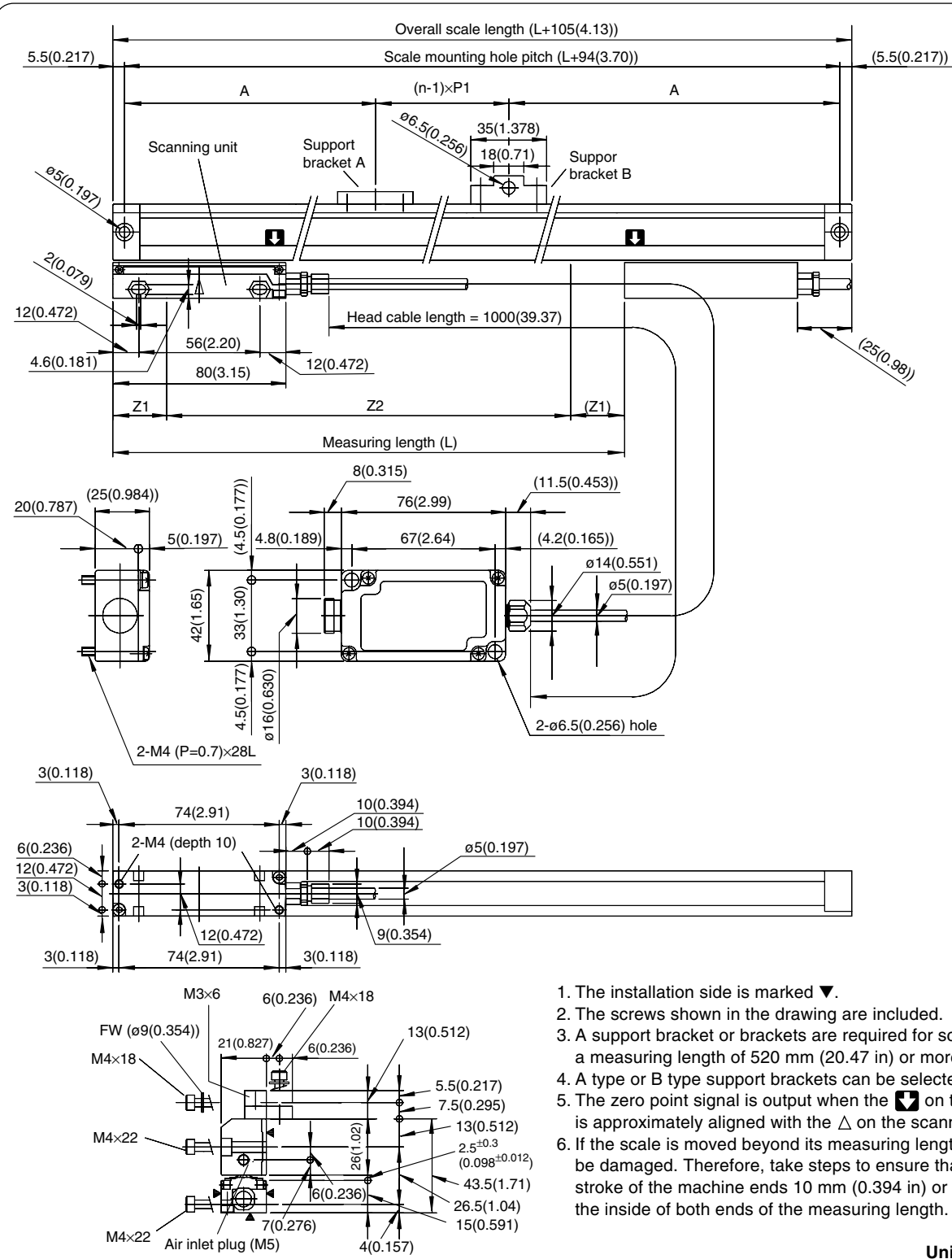

## Scale Unit Dimensions

Scale Model SH11-		007□□□2	012□□□2	017□□□2	022□□□2
Measuring length	L [mm(in)]	70(2.76)	120(4.72)	170(6.69)	220(8.66)
Support bracket	n (No.)	—	—	—	—
Support bracket	A [mm(in)]	—	—	—	—
Mounting hole pitch	P1 [mm(in)]	—	—	—	—
Zero point position	Z1 [mm(in)]	35(1.38)	35(1.38)	35(1.38)	35(1.38)
	Z2 [mm(in)]	—	50(1.97)	100(3.94)	150(5.91)

Scale Model SH11-		027□□□2	032□□□2	037□□□2	042□□□2
Measuring length	L [mm(in)]	270(10.63)	320(12.60)	370(14.57)	420(16.54)
Support bracket	n (No.)	—	—	—	—
Support bracket	A [mm(in)]	—	—	—	—
Mounting hole pitch	P1 [mm(in)]	—	—	—	—
Zero point position	Z1 [mm(in)]	35(1.38)	35(1.38)	35(1.38)	35(1.38)
	Z2 [mm(in)]	200(7.87)	250(9.84)	300(11.81)	350(13.78)

Scale Model SH11-		047□□□2	052□□□2	057□□□2	062□□□2
Measuring length	L [mm(in)]	470(18.50)	520(20.47)	570(22.44)	620(24.41)
Support bracket	n (No.)	—	1	1	1
Support bracket	A [mm(in)]	—	307(12.09)	332(13.07)	357(14.06)
Mounting hole pitch	P1 [mm(in)]	—	—	—	—
Zero point position	Z1 [mm(in)]	35(1.38)	35(1.38)	35(1.38)	35(1.38)
	Z2 [mm(in)]	400(15.75)	450(17.72)	500(19.69)	550(21.65)

Scale Model SH11-		067□□□3	072□□□3	077□□□3	082□□□3
Measuring length	L [mm(in)]	670(26.38)	720(28.35)	770(30.31)	820(32.28)
Support bracket	n (No.)	1	1	1	1
Support bracket	A [mm(in)]	382(15.04)	407(16.02)	432(17.01)	457(17.99)
Mounting hole pitch	P1 [mm(in)]	—	—	—	—
Zero point position	Z1 [mm(in)]	35(1.38)	35(1.38)	35(1.38)	35(1.38)
	Z2 [mm(in)]	600(23.62)	650(25.59)	700(27.56)	750(29.53)

Scale Model SH11-		092□□□3	102□□□3	114□□□3	124□□□3
Measuring length	L [mm(in)]	920(36.22)	1020(40.16)	1140(44.88)	1240(48.82)
Support bracket	n (No.)	1	2	2	2
Support bracket	A [mm(in)]	507(19.96)	380(14.96)	420(16.54)	450(17.72)
Mounting hole pitch	P1 [mm(in)]	—	354(13.94)	394(15.51)	434(17.09)
Zero point position	Z1 [mm(in)]	35(1.38)	35(1.38)	45(1.77)	45(1.77)
	Z2 [mm(in)]	850(33.46)	950(37.40)	1050(41.34)	1150(45.28)

## 2-2. Installation Design

Installing the product incorrectly may shorten its life or affect its performance. Design the installation surface and mounting bracket in accordance with the checkpoints given below.

### Selecting the Mounting Location

To obtain full performance from the scale unit, select a mounting location that satisfies the following criteria:

- Not subject to vibration or dust
- As close as possible to the machine's cutting tool to guarantee machining accuracy
- A place that ensures ease of scale unit maintenance
- A place that enables smooth installation

### Checking the Measuring Length

Select a scale with a measuring length that extends at least 10 mm (0.394 in) from both ends of the machine's maximum stroke. If there is a possibility that the machine might exceed the scale measuring length, install mechanical stoppers or otherwise restrict the machine's range of movement.

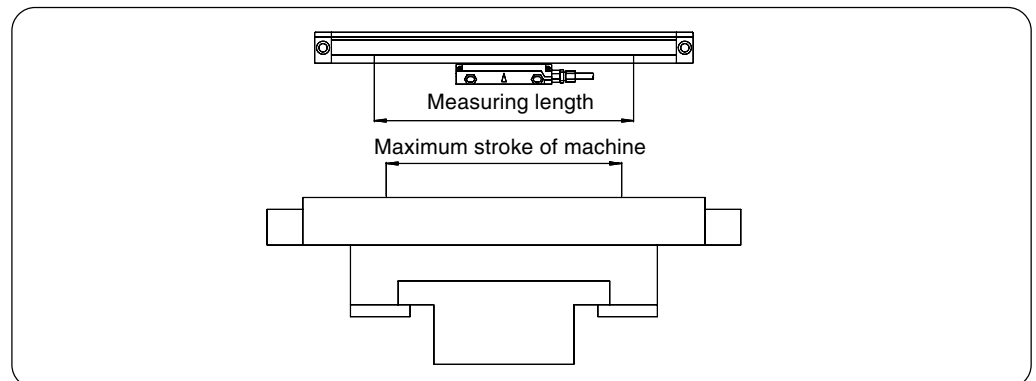

#### Note

The scale will be damaged if it moves beyond the measuring length.

### Installation Direction

Although the traveling part of the scale unit is partially sealed, it is not completely sealed off for structural reasons. When mounting the scale to the horizontal axis, install it so that the opening points downwards. When mounting the scale to the vertical axis, install it so that the opening points to the outside, away from the cutting tool.

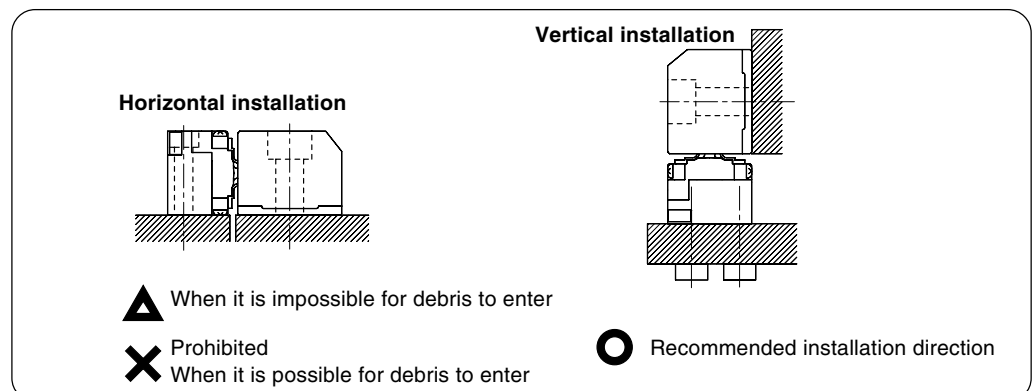

## Flatness and Parallelism of the Installation Surface

- The installation surface of the scale unit should be finished along its entire length to finish symbol  $\sqrt{6.3S}$  or better and should be machined to a flatness of 0.05 mm (0.002 in)/M (where M is the machine guide's length).

If the scale overhangs the machine, it must be reinforced with a backplate made of flat polished steel plate at least 12 mm (0.472 in) thick. Ensure that the installation surface is free of gouges or flaws.

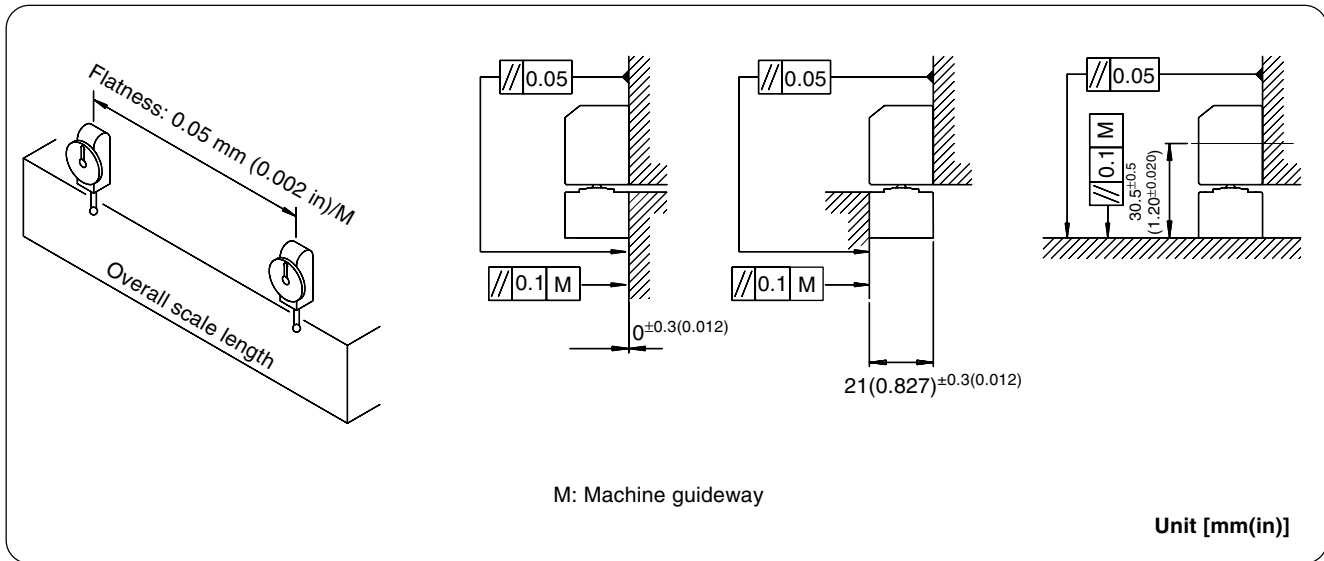

- Design the installation surface so that the parallelism of the installation surface and the scale in the vicinity of each scale mounting screw is 0.05 mm (0.002 in).

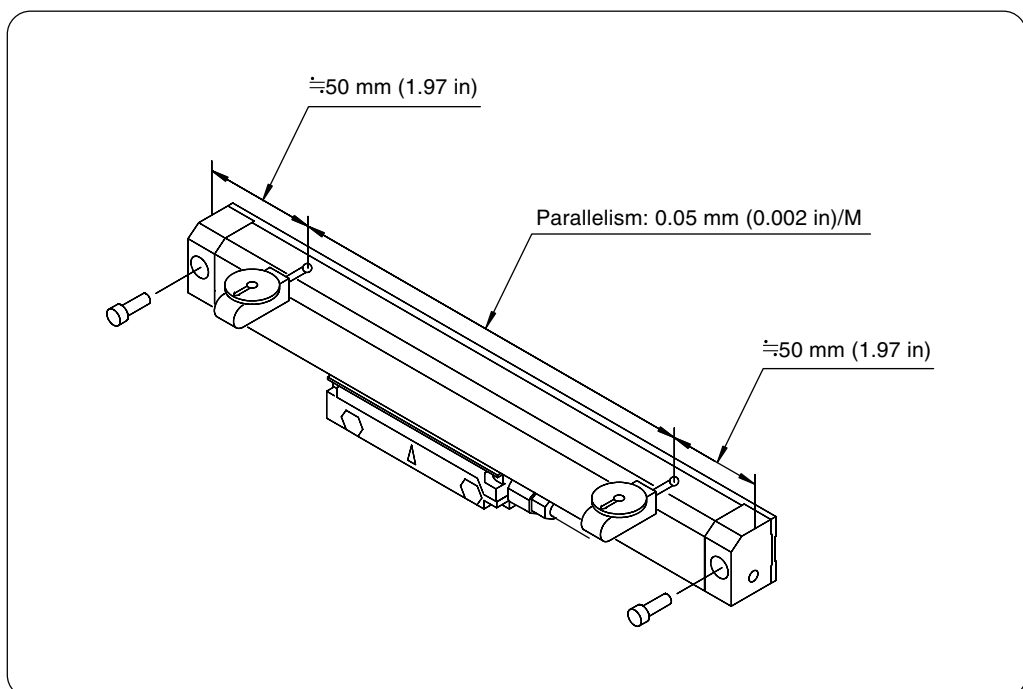



**Designing the Scanning Unit Mounting Bracket**

- The mounting bracket should be designed to have adequate rigidity relative to the direction of travel.

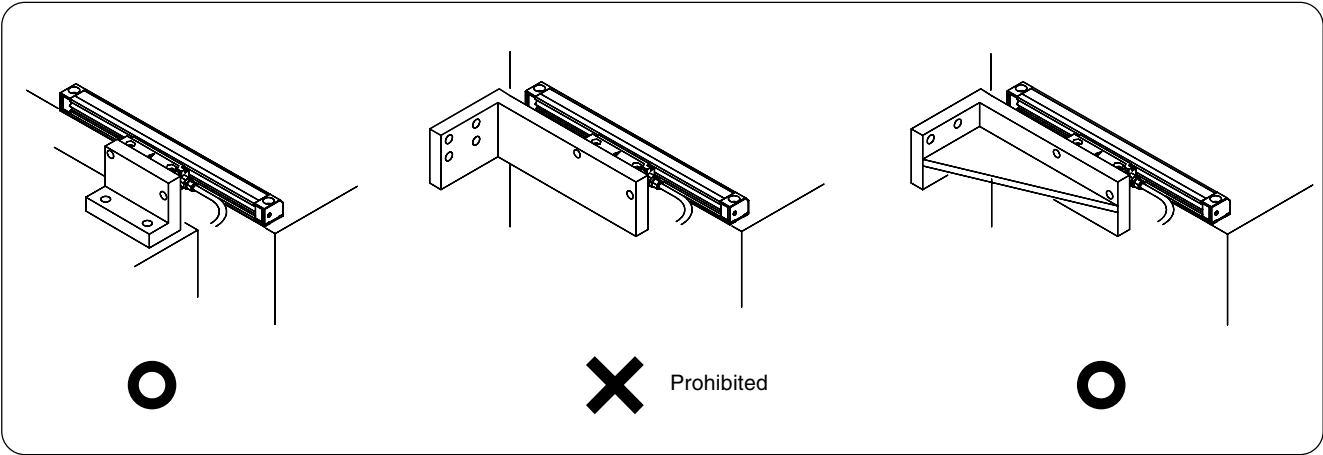

**Ensuring Sufficient Maintenance Space**

- The scale unit must be removed when replacing the scanning or detector unit. Therefore, ensure sufficient space for removing the scale unit.

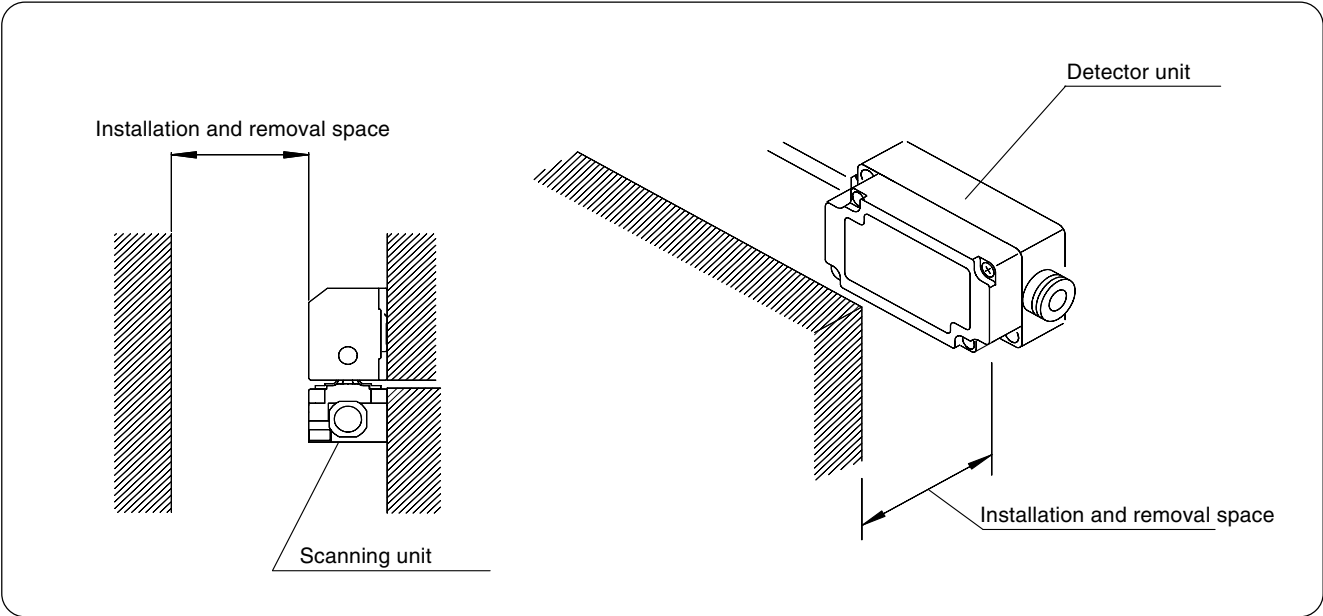

## 2-3. Installation Procedure

The installation procedure for the scale unit is explained below. Note that the following components must not be disassembled, as doing so may cause breakdowns.

- [Do not Disassemble the Following]
- Mechanical and electrical components of the scanning unit
  - Scale unit cable connectors
  - Glass scale

The scale unit is composed of precision components, so applying undue force may adversely affect the precision and life of the unit. Ensure that undue force is not exerted on the scale unit during operation.

Support the main body of the scale unit and scanning unit during transport. Do not lift by the cables or connectors.

### 2-3-1. Installing the Scale Unit

#### 1. Checking the Flatness of the Scale Unit Installation Surface

- Check that the installation surface of the scale unit is finished along its entire length to finish symbol  $\sqrt{6.3S}$  or better, and check that it has a flatness of 0.05 mm (0.002 in)/M (where M is the machine guide's length).

#### 2. Installing the Support Bracket to the Scale

- A support bracket or brackets are supplied with scales which have a measuring length of 520 mm (20.47 in) or more.
- Fixing nuts for the support brackets are inserted in the slit on the top face of the scale. Install the support bracket or brackets using hexagonal socket head cap screws (M3×6). Using a torque wrench, tighten to a torque of 1.5 N•m.
- Position the support bracket at the center of the scale. For scales with a measuring length of 1020 mm (40.16 in) or more, position the support brackets so that the scale is divided into equal parts.
- Either support bracket A or B can be selected.

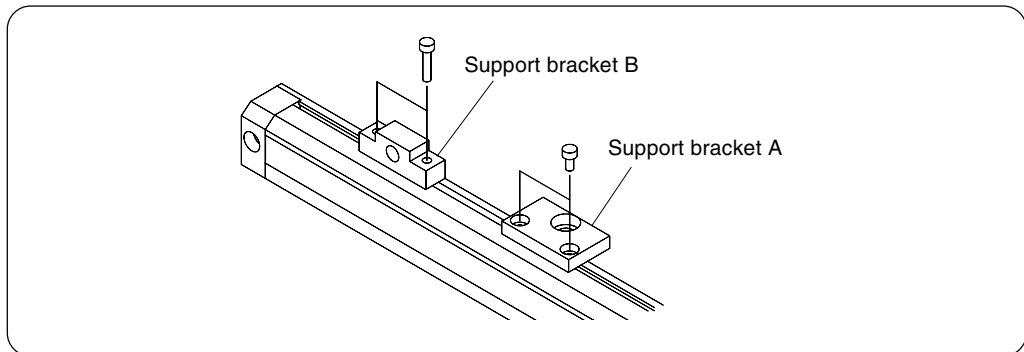

#### 3. Temporarily Securing the Scale Unit

- Move the movable machine part to roughly the center of the stroke and lightly secure it with the supplied hexagonal socket head cap screws (M4×22).

#### 4. Temporarily Securing the Support Bracket

- Temporarily secure the scale unit, then lightly secure the support bracket with the supplied hexagonal socket head cap screws (M4×18).

## 5. Checking the Parallelism of the Scale Unit

- Place a dial gauge on the top face of the scale unit and check its parallelism.
- The tolerance for the parallelism is 0.05 mm (0.002 in) in the vicinity of each scale mounting screw. Adjust the scale unit so that the reading comes within this range.

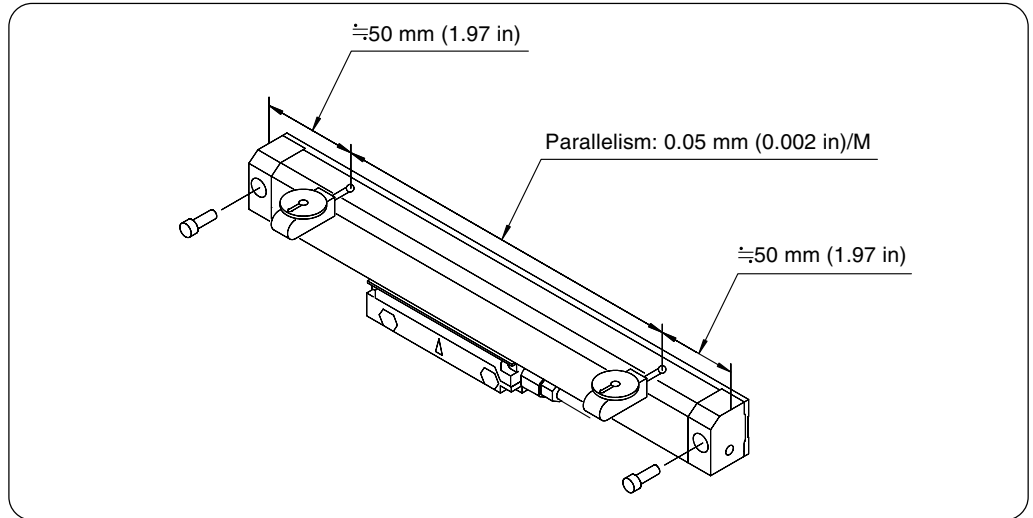

## 6. Securing the Scale Unit

- After checking the flatness and parallelism, tighten the hexagonal socket head cap screws. Using a torque wrench, tighten to a torque of 2 N•m. Do not completely tighten the hexagonal socket head cap screws one by one; rather, tighten all screws evenly.

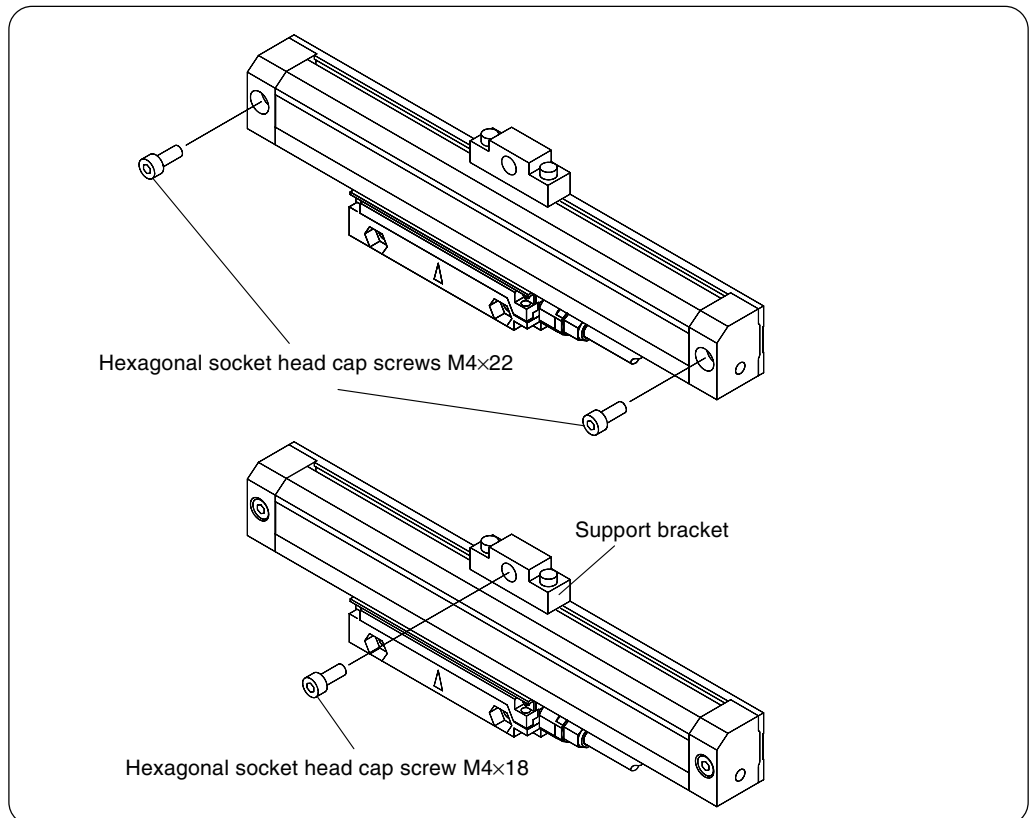

## 2-3-2. Securing the Scanning Unit to the Mounting Bracket

When mounting the scanning unit into the mounting bracket, always make sure both slider holders L and R are attached.

If slider holders L and R become detached, remount them.

When installing slider holders L and R for the first time, insert them into the scale groove from the ends of the scale.

Inserting slider holders L and R into the scanning unit will determine the relative positions of the scale and scanning unit.

Twisting the scanning unit while the slider holders are not in use may dislodge the scanning unit dust seal from the dust seal guide groove. If the dust seal becomes dislodged, it can be refitted without any problems. However, be careful not to dislodge it during the installation work.

### 1. Checking Slider Holders L and R

- Check to make sure slider holders L and R are attached. If they have become detached, remount them.

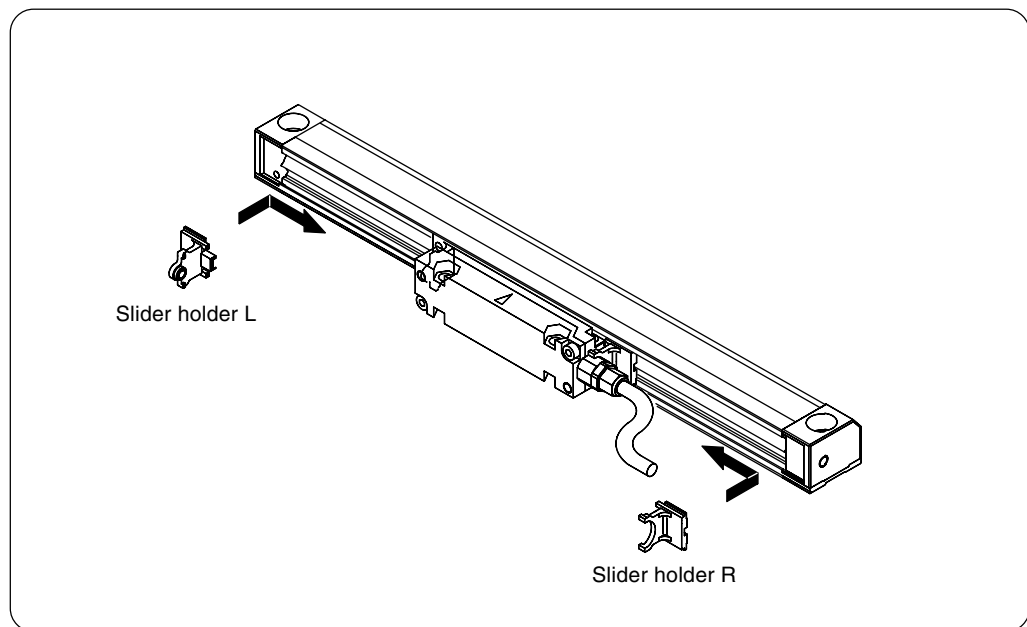

### 2. Checking for Installation Errors

- The mounting tolerance for the positions and height of the scale unit and scanning unit is  $\pm 0.3$  mm (0.012 in). If there is a gap between the scanning unit and the mounting bracket, adjust with spacers or similar items. If the mounting bracket is too high, switch to a lower mounting bracket.

### 3. Securing the Scanning Unit

- With the scanning unit supported by slider holders L and R, slide it into the installation position and secure it in place with the hexagonal socket head cap screws (M4×22). Using a torque wrench, tighten to a torque of 2 N•m.

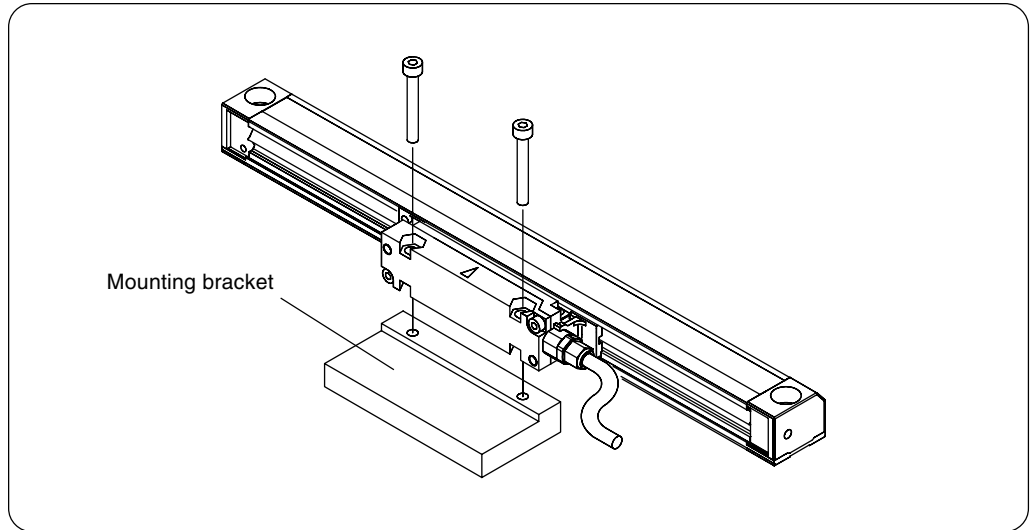

### 2-3-3. Removing the Slider Holders

#### 1. Checking the Cap Screw Tightness

- Before removing the slider holders, double-check to make sure the scale and scanning unit mounting cap screws are tightened.

#### 2. Removing Slider Holders L and R

- Take out slider holders L and R from the ends of the scale.
- Trying to move the scale before removing the slider holders may damage the scale.

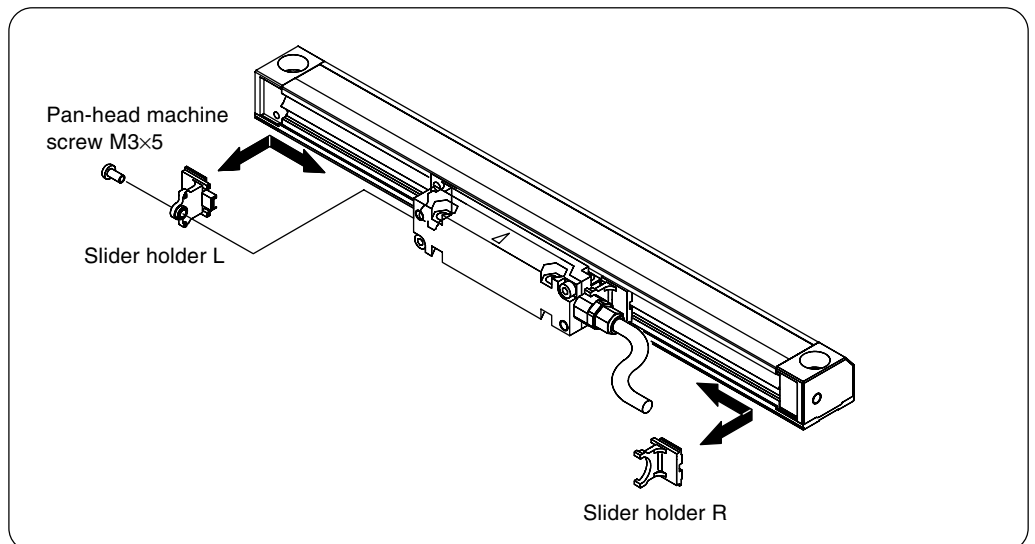

## 2-3-4. Cable Management

---

### Managing Cables

- Manage cables so that they do not hinder machine operations or become entangled. Handle cables carefully, as forceful pulling or repeated bending may damage them.
- The connector of the head cable has been waterproofed, but ensure that it is fitted in a location where it is not exposed to chips or cutting fluid.

---

### Minimum Cable Bending Radius

- Ensure that cables are arranged so that their bending radius tolerances are not exceeded.
- The cable bending radii are as follows:

#### Head Cable

When the cable does not move during use ... Bending radius: 30 mm (1.18 in) or more  
When the cable moves during use ..... Repeated bending not permitted  
(Secure with a bending radius of 30 mm (1.18 in) or more.)

#### Connecting Cable

When the cable does not move during use ... Bending radius: 50 mm (1.969 in) or more  
When the cable moves during use ..... Bending radius: 100 mm (3.937 in) or more

---

### Securing Cables

- Secure the head cable with cable clamps or similar items near the outlet. Also, secure the connecting cable firmly so that it does not hinder machine operations or become entangled.

---

### Protecting the Connecting Cable Polarity Switch

- A polarity switch is attached to the connector that leads to the control unit. This switch can be reversed to suit the reading direction of the scale.

**Note**

This switch can be operated during use, but doing so is very dangerous, as this reverses the feedback signal.

Attach a protective cover to the polarity switch on the connector that leads to the control unit so that it cannot be operated accidentally.

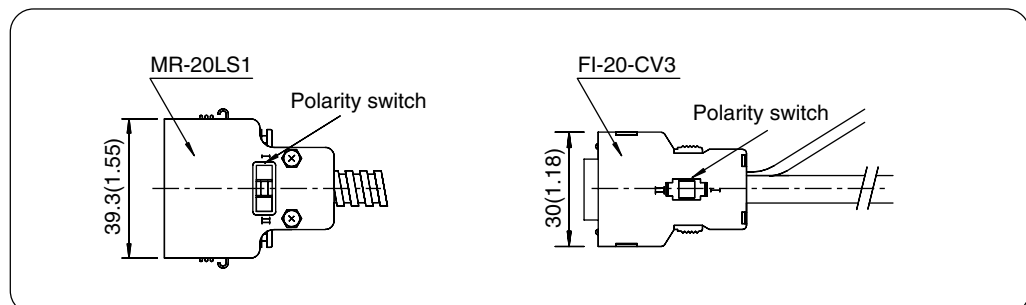

## **2-3-5. Precautions when the Scanning Unit is Connected to a Movable Component**

Mounting the scale unit to a movable part and the scanning unit to a fixed part is ideal, but if the reverse is necessary for structural reasons, the following points should be noted:

---

### **Managing the Head Cable**

- Secure the head cable and allow the connecting cable to bend.
- Secure the largest bending radius possible for the head cable.
- The allowable bending radius for the head cable is 30 mm (1.18 in) or more.

---

### **Managing the Connecting Cable**

- Secure the connecting cable firmly so that it does not hinder machine operations or become entangled. The cable getting caught on the operator or objects in the vicinity presents a hazard. Furthermore, even if it does not appear so from the outside, the internal core wire may be severed.
- The allowable bending radius of the connecting cable is 100 mm (3.937 in) or more. The cable wires may be severed if subjected to repeated bending at radii smaller than this.

---

### **Extending the Connecting Cable**

- Do not extend the connecting cable to a length of more than 30 m (1181.10 in).

### 2-3-6. Connection Example (Reference)

The drawing below shows an example of an interface. When using a 26LS32, attach external resistance of 150  $\Omega$ , since the IC does not have an internally terminated resistor ( $R_t$ ). The drawing below also shows the open circuit alarm detection circuit.

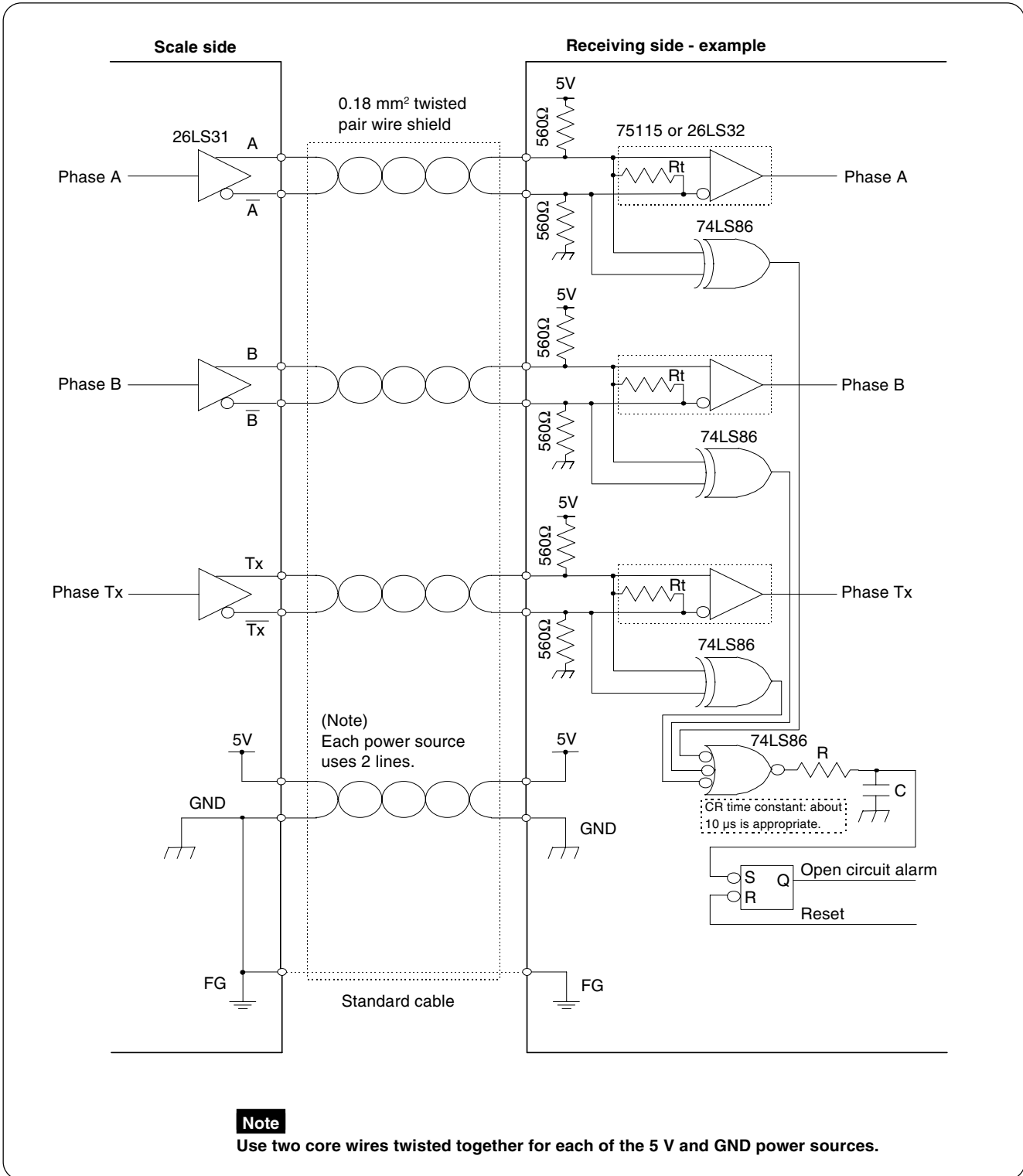



## 2-4. Managing the Operating Environment

### Installation Direction

- Although the traveling part of the scale unit is partially sealed, it is not completely sealed off for structural reasons. When mounting the scale to the horizontal axis, install it so that the opening points downwards. When mounting the scale to the vertical axis, install it so that the opening points to the outside, away from the cutting tool.

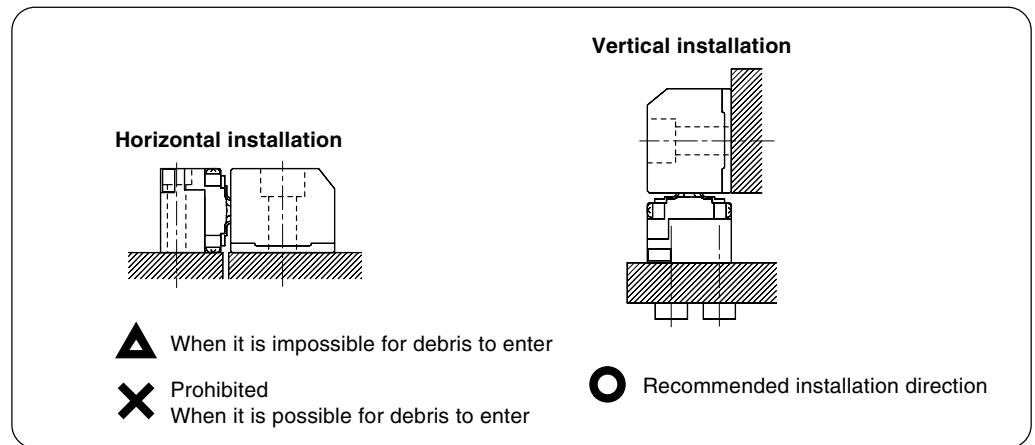

### Protective Cover

- Attach a protective cover with the necessary strength if the scale is installed in a location where the operator may place his elbows or legs.
- Preferably, choose a mounting location where the scale will not be exposed to chips or cutting fluid. If that is impossible, attach an appropriate cover.

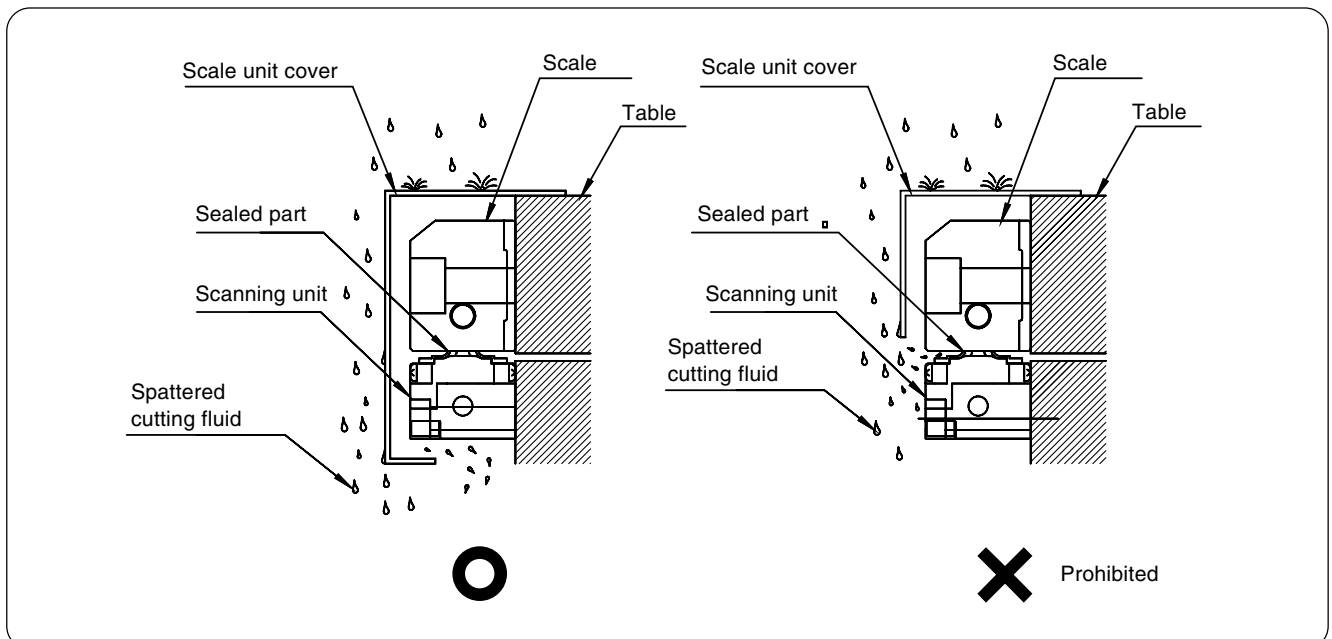

## 2-5. Air Purge

The scale bracket is fitted with standard M5 tap holes on both sides to allow air intake. If the scale unit is to be used in the environments listed below, harmful effects can be reduced by blowing clean air into the unit.

- **Dusty locations**
- **Highly humid locations**
- **Locations where changes in temperature and humidity give rise to condensation**

As the efficacy of introducing air depends on the service conditions, do so only after verifying the effectiveness.

### Air Tubing Route and Equipment Configuration

- Take into consideration the tubing route and other factors when choosing between the left and right air intake ports.  
Note that the air intake ports are capped with M5×5 hexagonal socket head locking screws, which should be removed before use.
- Prepare the equipment and tubing as shown in the figure below to allow air to be introduced into the scale unit.

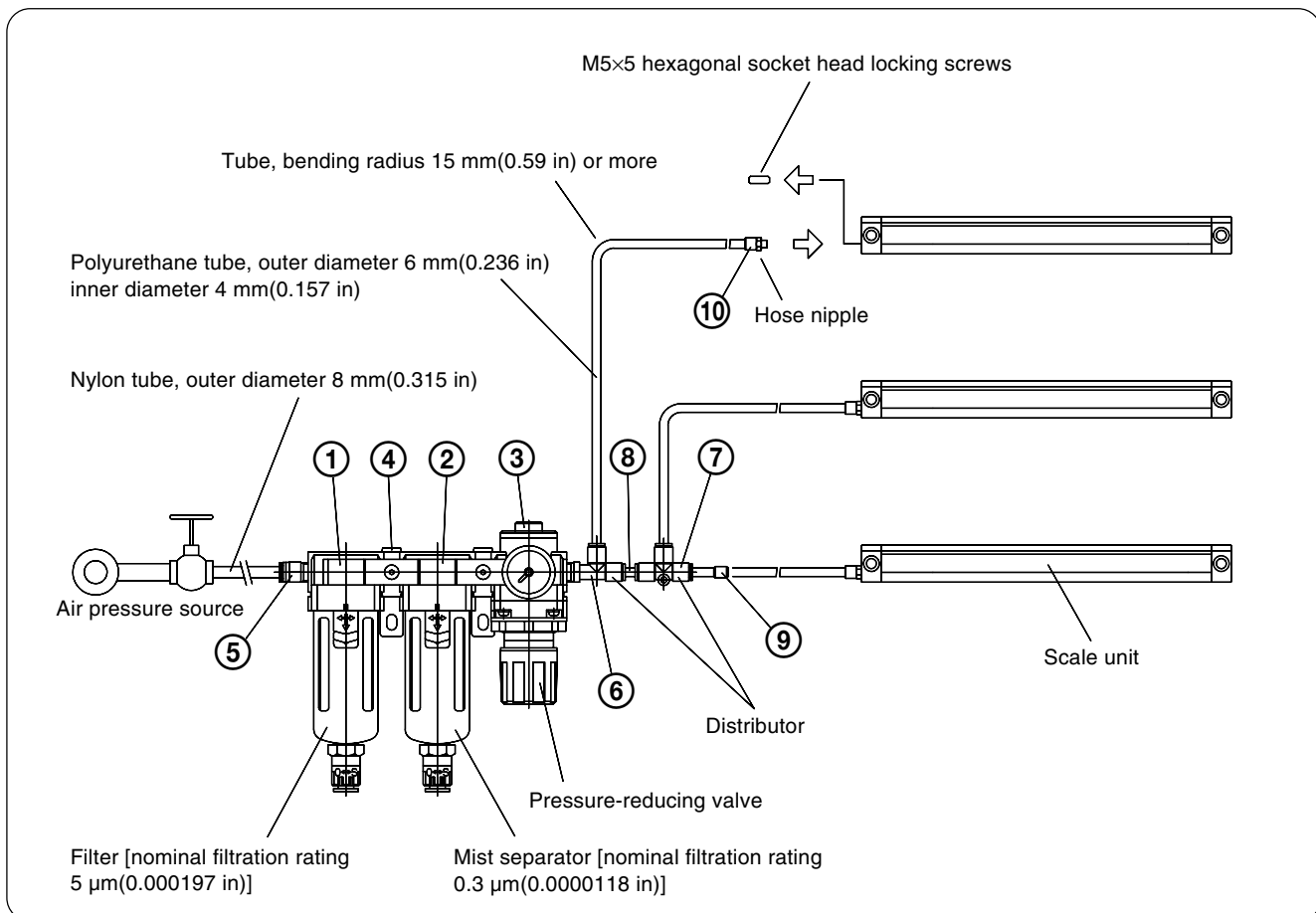

- The air supply unit and fittings should be provided by the customer.  
The tables below provide standard equipment specifications and component parts (manufacturers) for reference.

### Specifications

Item	Specification
Proof pressure	1.5 MPa
Maximum service pressure	1020 kPa
Set pressure range	20 to 200 kPa
Service fluid	Air
Ambient temperature and service fluid temperature	-5 to +60°C (33 to 140°F) (must not freeze)
Nominal filtration rating	Air filter: 5 µm (0.000197 in) Mist separator: 0.3 µm (0.0000118 in)
Pressure gauge connection diameter	2-Rc (PT) 1/8
Tubing connection diameter	IN side: Outer diameter of tube 8 mm (0.315 in) (one location) OUT side: Outer diameter of tube 6 mm (0.236 in) (three locations)
Auto drain differential pressure	150 to 1020 kPa

### Component Parts

Part No.	Model No.	Name	Quantity	Manufacturer
1	AF3000-02C	Air filter (nominal filtration rating: 5 µm (0.000197 in))	1	SMC
2	AFM3000-02C	Mist separator (nominal filtration rating: 0.3 µm (0.0000118 in))	1	SMC
3	AR3000-02G-1	Pressure-reducing valve	1	SMC
4	Y30L	Spacer assembly with L-shaped bracket	2	SMC
5	KQH08-02S	Half-union	1	SMC
6	KQY06-02S	Service cheese union	1	SMC
7	KQT06-00	Cheese	1	SMC
8	KQN06-99	Nipple	1	SMC
9	KQP-06	Plug	3	SMC
10	M-5H6	Hose nipple	3	SMC

## Tubing

### Tube Installation

Ensure a tube bending radius of 15 mm (0.59 in) or more, and do not allow the tube to bend sharply. Also, when installing tubes in parallel in electrical, hydraulic or other ducts, make sure that the movement of the duct does not cause the tube to collapse.

### Tube Length

To match the air intake pressure into each scale unit, always ensure that the tubes from the air supply unit distributors to the intake ports are the same length.

### Pressure-Reducing Valve Set Pressure and Tube Length

If the intake air pressure into each scale unit is around  $20 \pm 10$  kPa, the humidity of the air in the scale unit can be kept low. However, the length of the tube precludes the use of the pressure-reducing valve to obtain an intake air pressure of  $20 \pm 10$  kPa. Determine the set pressure for the pressure-reducing valve with reference to the diagram below, "Pressure-Reducing Valve Set Pressure and Tube Length".

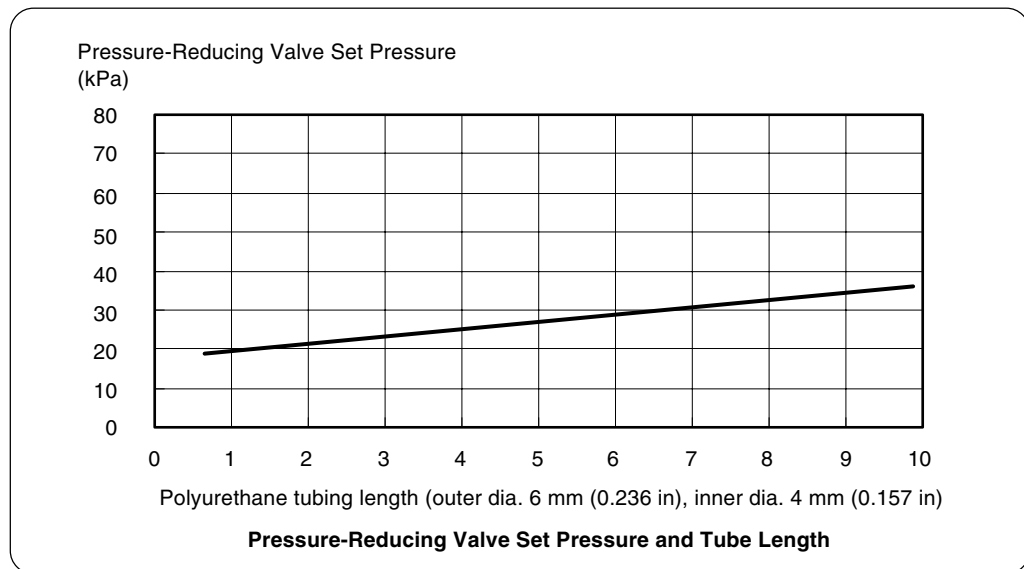

This diagram shows the relationship between the set pressure for the pressure-reducing valve and the tube length for an intake air pressure of 20 kPa.

Tube length here means the length from the distributor of the air supply unit to the intake port of the scale unit.

When the intake air pressure is 20 kPa, the amount of air consumed for each unit is approximately  $30 \text{ N } \ell / \text{min}$ .

### Flushing the Tubing

Using the air source, flush the air supply unit connection and the inlet portion leading into the scale. This cleans the tubing, prevents debris from getting caught in the machinery, and also serves as a check for the tubing.

### Air Pressure Source

When using a compressor as the air pressure source, select an appropriate compressor in consideration of the volume of air to be consumed (approx. 30 N ℓ /min. per unit). The following diagram, "Delivery Capacity and Rated Output", may provide some assistance in choosing the compressor, but note that specifications vary between different models.

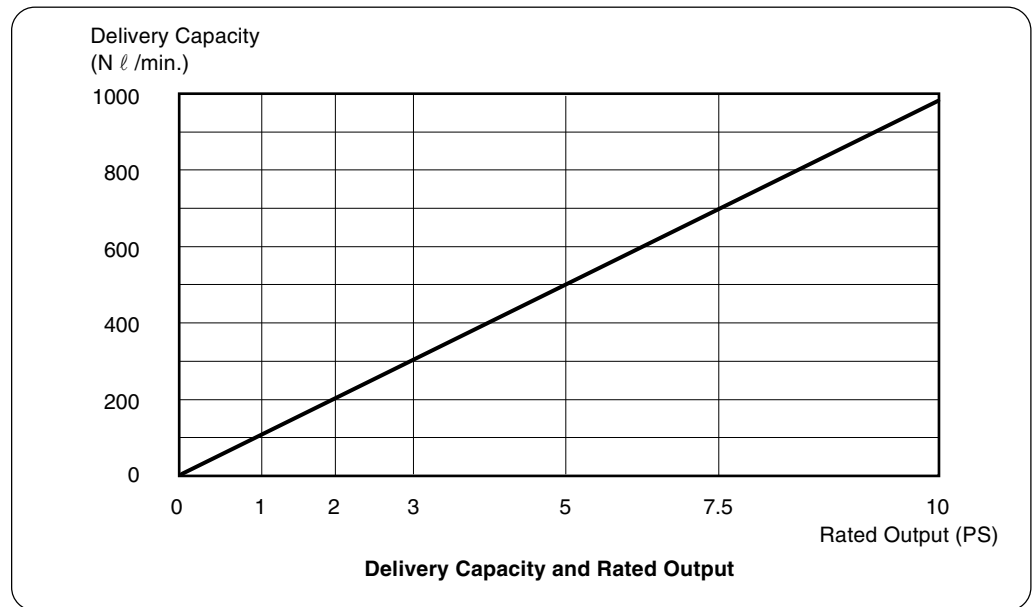



# Chapter 3 Maintenance

## 3-1. Start-up Inspection

### Checking for Open Circuits

The scanning unit is normally connected to the control unit by a connecting cable through the cable (head cable) from the scanning unit. Both the head cable and connecting cable must be checked if there is an open circuit. Shake the movable parts of the head cable and connecting cable and confirm that the open circuit alarm is not displayed on the control unit. If it is, the severed cable unit must be repaired. It is extremely dangerous to continue operations without repairing the cable; immediately stop the machine and contact your Sony Manufacturing Systems Corporation distributor.

While checking the head cable, pay close attention to the connection with the scanning unit and the junction connector. Also, when using a conduit connecting cable, check very carefully as there may be open circuits caused by microscopic chips.

### Checking for Dust Lip Wear

Look at the underside of the scale, and check to see if the edge of the dust lip is worn. If it is, the scale glass and inside detector part must be cleaned and the dust lip replaced. Contact your Sony Manufacturing Systems Corporation distributor.

### Checking for Odd Noises

Slowly move the machine and listen to see if any odd noises occur. If so, the scale main body and scanning unit may be in contact. Continuing operation in this condition may lead to major breakdowns, so stop the machine immediately and contact your Sony Manufacturing Systems Corporation distributor.

### Strictly Enforce Cleaning

Ensure that chips are cleaned up before starting work and at the end of work each day to prevent them from building up around the scale. Otherwise, chip buildup may prevent the scale from sliding and cause breakdowns. **Avoid using air guns or similar devices** for cleaning, because while the traveling part of the scale unit is sealed, it is not completely sealed off for structural reasons. Use of an air gun may cause chips or other debris to penetrate into the scale and cause breakdowns.

## 3-2. Regular Inspections

### Presence of Condensation

If mist, condensation, dust or coolant (water-miscible cutting fluid) are present on the dust lip of the scale unit, strengthen the cover and supply air to the unit.





# Chapter 4 Specifications

## 4-1. General Specifications and Performance Specifications

### General Specifications

Item	Specification
Service temperature range	0°C to +45°C (32°F to 113°F)
Storage temperature range	-10°C to +60°C (14°F to 141°F)
Service humidity range	Relative humidity 30% to 90% (no condensation)
Rate of change of temperature, humidity	A rate that does not cause condensation
Service environment	No corrosive gas
Vibration resistance	68.6 m/s <sup>2</sup> or less (30 to 1000 Hz for 30 min.)
Impact resistance	147 m/s <sup>2</sup> or less (11 ms X, Y, Z directions, three times each)

### Performance Specifications

Item	Specification
Detection system	Optical Moiré fringe detection system (transmission model)
Output system	Two-phase signal (Phase A, Phase B), Line driver output
Light source and light-receiving device	Infrared light-emitting diode, photodiode
Measuring length [mm(inch)]	20 lengths: 70(2.76), 120(4.72), 170(6.69), 220(8.66), 270(10.63), 320(12.60), 370(14.57), 420(16.54), 470(18.50), 520(20.47), 570(22.44), 620(24.41), 670(26.38), 720(28.35), 770(30.31), 820(32.28), 920(36.22), 1020(40.16), 1140(44.88), 1240(48.82)
Maximum response speed	Resolution: 0.05 μm, t = 0.16 μs, 12 m/min. t = 0.3 μs, 6 m/min. Resolution: 0.1 μm, t = 0.16 μs, 24 m/min. t = 0.3 μs, 12 m/min.
Zero point detection speed	0.05 μm 0.01 to 0.05 m/min 0.1 μm 0.01 to 0.2 m/min
Scale resolution	0.05 μm (0.00000195 in), 0.1 μm (0.0000039 in)
Glass grating pitch	16 μm (0.00063 in)
Scale zero point	One point in the center for a measuring length of 70 mm (2.756 in), otherwise, two points at the left and right ends inside the measuring length.
Scale precision	Measuring length 70(2.76) to 620(24.41) mm(in): ±2 μm 670(26.38) to 1240(48.82) mm(in): ±3 μm
Allowable mounting parallelism	0.05 mm (0.00197 in)
Precision proof temperature	20°C (68°F)
Glass thermal expansion coefficient	(8.8 ± 1) × 10 <sup>-6</sup> /°C
Protection class	IP53 (when used in accordance with the instruction manual)
Power supply and current consumption	DC +5 V ±5%, 250 mA

## 4-2. Resolution and Response Speeds

### Relationship between Resolution and Maximum Response Speed

Model	Resolution	Min. Phase Difference	Grating Pitch	Max. Response Speed
SH11-□□□B1A□	0.05 μm	0.16 μs	16 μm	12 m/min
SH11-□□□B1B□	0.05 μm	0.3 μs	16 μm	6 m/min
SH11-□□□C1A□	0.1 μm	0.16 μs	16 μm	24 m/min
SH11-□□□C1B□	0.1 μm	0.3 μs	16 μm	12 m/min

### Relationship between Resolution and Zero Point Detection Speed

Model	Resolution	Min. Phase Difference	Zero Point Detection Speed Range
SH11-□□□B1A□	0.05 μm	0.16 μs	0.01 to 0.05 m/min
SH11-□□□B1B□	0.05 μm	0.3 μs	0.01 to 0.05 m/min
SH11-□□□C1A□	0.1 μm	0.16 μs	0.01 to 0.2 m/min
SH11-□□□C1B□	0.1 μm	0.3 μs	0.01 to 0.2 m/min

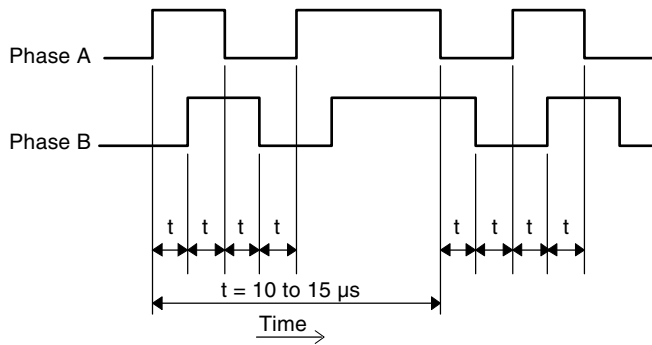

Example of output waveform (Symbol: C1,  $t = 0.3 \mu\text{s}$ )

- Connect to a control unit able to read the minimum phase difference ( $t$ ).
- Set the minimum phase difference able to be read by the control unit so that  $X < t$  when the (X) scale minimum phase difference is set to ( $t$ ).
- The A-phase and B-phase output signals are output at intervals. The figure at left shows an example when these signals are output at a fixed speed exceeding the zero point detection speed.

## 4-3. Electrical Characteristics

### 1. Output Waveform

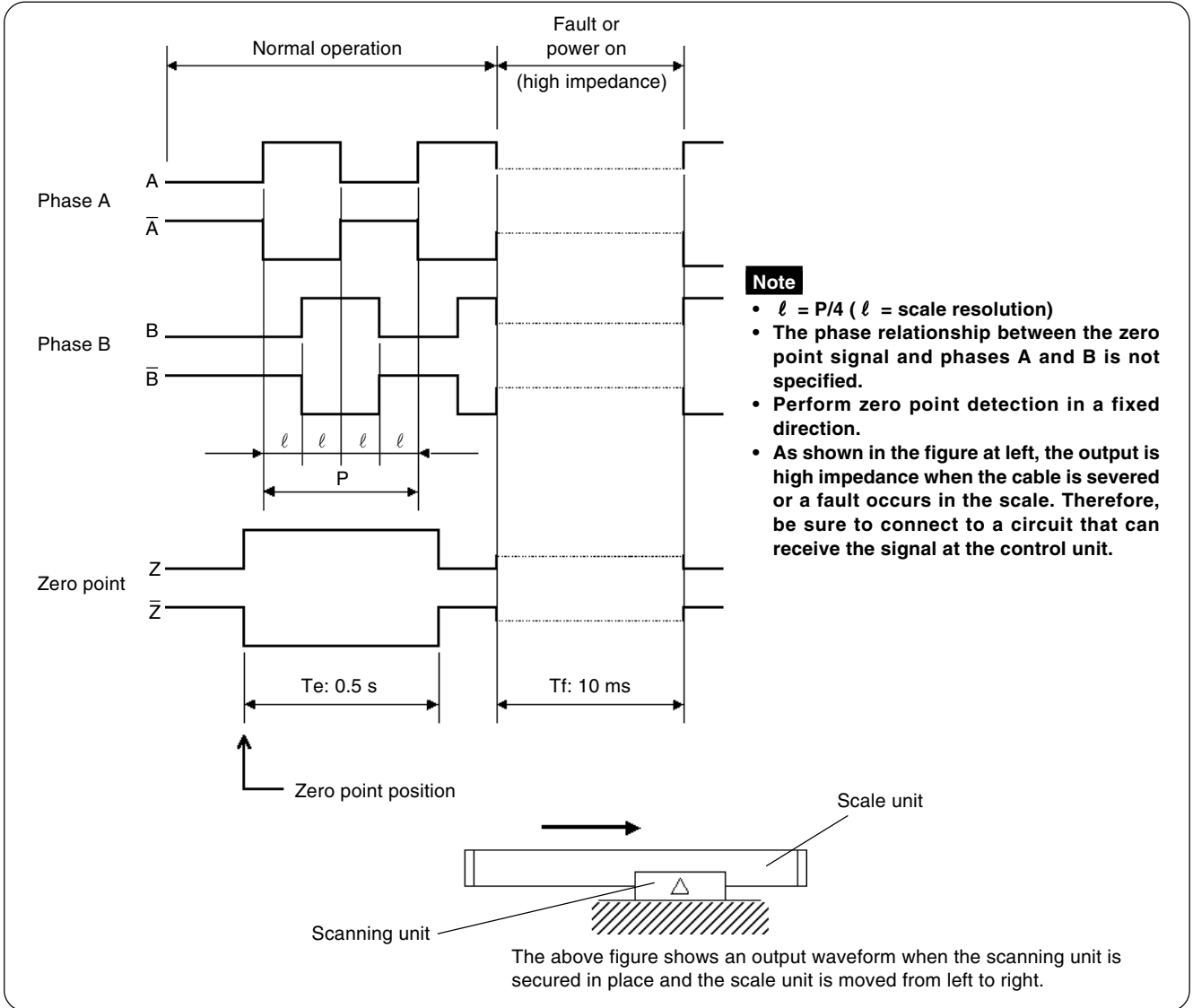

### 2. Output Format

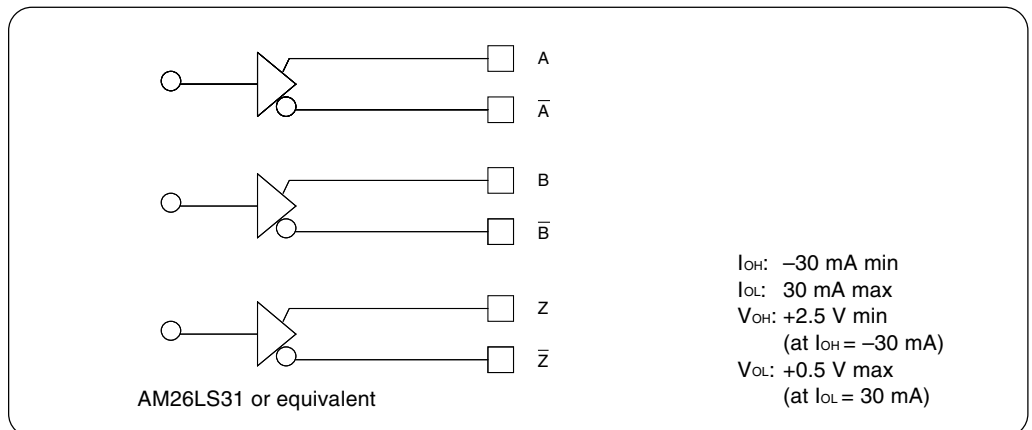

## 4-4. Cable Specifications

A connecting cable is used to join the scale unit and the control unit.

Whether or not to use a conduit connecting cable is specified by the shape of the terminal that leads to the control unit.

When used in an environment where there is a concern that the cable segment might be damaged, choose a conduit cable.

The connector has a dust-proof, drip-proof construction (except for the connector that leads to the control unit).

The connector that leads to the control unit is fitted with a polarity switch, which can be used to reverse the scale reading direction. This switch can be operated during use, but doing so is extremely dangerous as it reverses the feedback signal. Attach a cover or similar device to the polarity switch on the connector that leads to the control unit to prevent against accidental operation.

### Connecting Cable

Cable length	Model			
	MR connector	Mini Dsub connector		Frayed tip
	Conduit cable	Conduit cable	No conduit cable	No conduit cable
2 m (78.7 in)	CR1-02MC	—	CR1-02DC	—
3 m (118.1 in)	CR1-03MC	—	CR1-03DC	—
5 m (196.9 in)	CR1-05MC	CR1-05DC	—	CR1-05NN
7 m (275.6 in)	CR1-07MC	CR1-07DC	—	—
10 m (393.7 in)	CR1-10MC	CR1-10DC	—	CR1-10NN
15 m (590.6 in)	CR1-15MC	CR1-15DC	—	—
20 m (787.4 in)	CR1-20MC	CR1-20DC	—	CR1-20NN
30 m (1181.1 in)	CR1-30MC	CR1-30DC	—	CR1-30NN

**Model CR1-□□MC (MR connector, Conduit)**

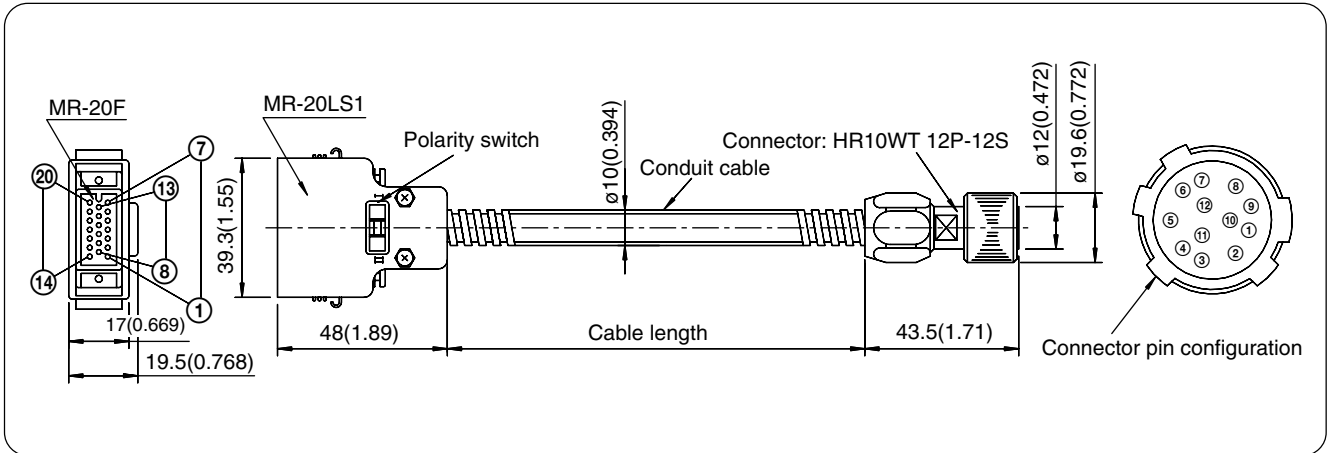

Unit [mm(in)]

**Wiring Chart**

Wire Color	MR-20F Pin No.	Signal Name	HR10WT Pin No.
Gray, purple	1, 2, 3	GND	6, 11
Shield	20	FG	7
Red	16	Phase A	2*
Orange	17	Phase $\bar{A}$	8*
Yellow	18	Phase B	3
Green	19	Phase $\bar{B}$	9
Black	14	Phase Z	4
Brown	15	Phase $\bar{Z}$	10 (Zero point)
Blue, white	4, 5, 6	+5 V	5, 12

\* This chart applies when the polarity switch on the connector is set to [I].  
When the polarity switch is set to [II], phases A and  $\bar{A}$  are substituted.

**Model CR1-□□DC (Mini Dsub connector, Conduit)**

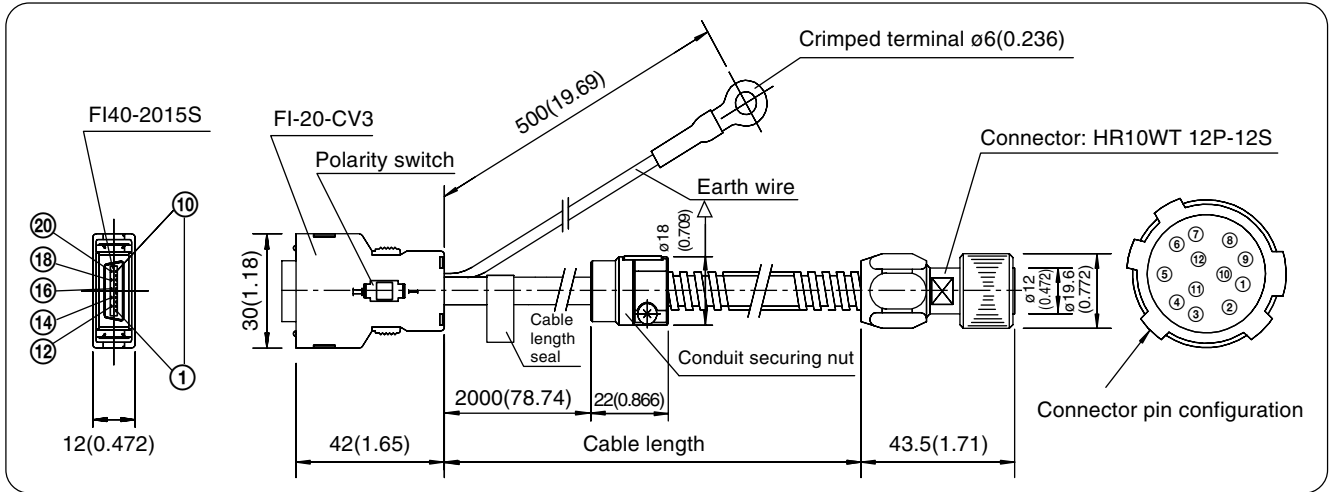

Unit [mm(in)]

**Model CR1-□□DC (Mini Dsub connector, No conduit)**

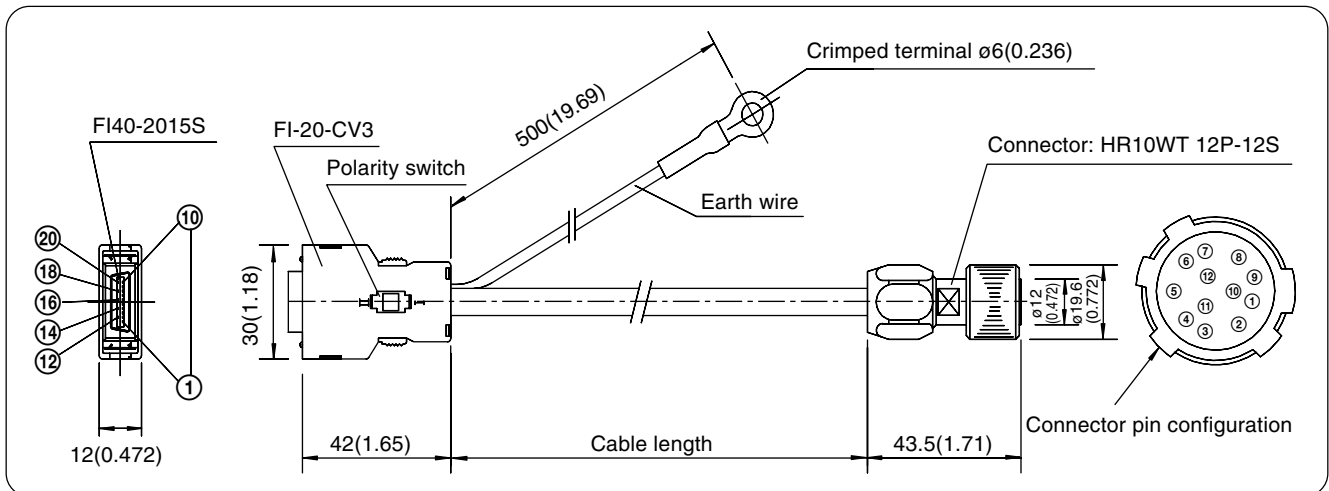

Unit [mm(in)]

**Wiring Chart**

Wire Color	FI40-2015S Pin No.	Signal Name	HR10WT Pin No.
Gray, purple	12, 14, 16	GND	6, 11
Shield	—	FG	7 (Earth wire)
Red	1	Phase A	2*
Orange	2	Phase $\bar{A}$	8*
Yellow	3	Phase B	3
Green	4	Phase $\bar{B}$	9
Black	5	Phase Z	4 (Zero point)
Brown	6	Phase $\bar{Z}$	10
Blue, white	9, 18, 20	+5 V	5, 12

\* This chart applies when the polarity switch on the connector is set to [I].  
When the polarity switch is set to [II], phases A and  $\bar{A}$  are substituted.

**Model** CR1-□□NN (Frayed tip, No conduit)

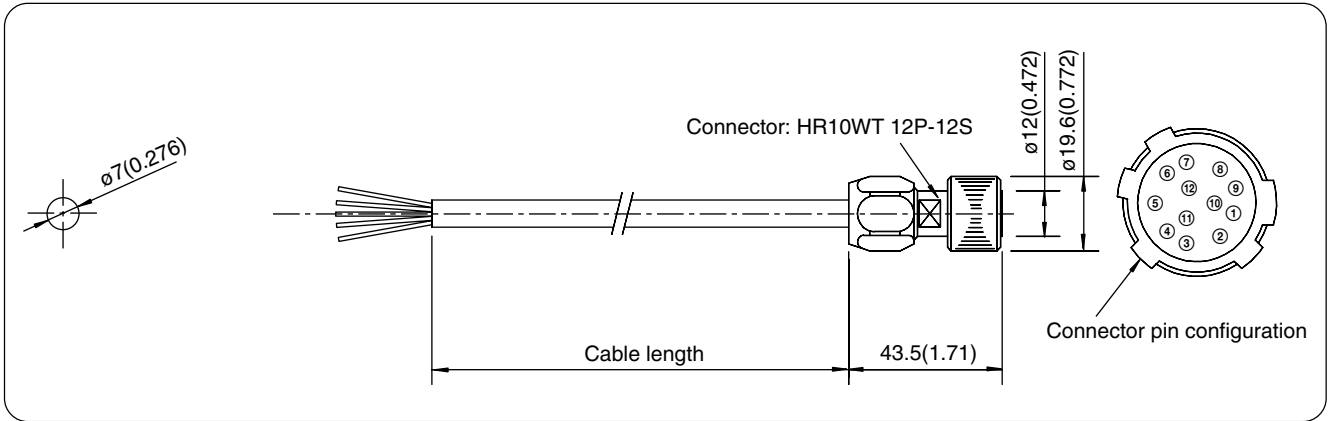

Unit [mm(in)]

**Wiring Chart**

Wire Color	Signal Name	HR10WT Pin No.
Gray, purple	GND	6, 11
Shield	FG	7
Red	Phase A	2
Orange	Phase $\bar{A}$	8
Yellow	Phase B	3
Green	Phase $\bar{B}$	9
Black	Phase Z	4 (Zero point)
Brown	Phase $\bar{Z}$	10
Blue, white	+5 V	5, 12

## Precautions When Using the Connecting Cable

- **Protecting the Connecting Cable Polarity Switch**

A polarity switch is attached to the connector which leads to the control unit. This switch can be reversed to suit the reading direction of the scale.

**Note**

This switch can be operated during use, but doing so is very dangerous, as this reverses the feedback signal.

Attach a protective cover to the polarity switch on the connector that leads to the control unit so that it cannot be operated accidentally.

- **Minimum Connecting Cable Bending Radius**

The connecting cable bending radii are as follows:

When the cable does not move during use ..... Bending radius: 50 mm (1.97 in) or more

When the cable moves during use ..... Bending radius: 100 mm (3.94 in) or more

- **Extending the Connecting Cable**

Do not extend the connecting cable to a length of more than 30 m (1181.1 in).



# Chapter 5 Appendix

## 5-1. Model Summary

**Scale Unit (Resolution: 0.05  $\mu\text{m}$  (0.00000195 in), minimum phase difference: 0.16  $\mu\text{s}$ )**

Measuring length	Model	Measuring length	Model
70 (2.76)	SH11-007B1A2	670 (26.38)	SH11-067B1A3
120 (4.72)	SH11-012B1A2	720 (28.35)	SH11-072B1A3
170 (6.69)	SH11-017B1A2	770 (30.31)	SH11-077B1A3
220 (8.66)	SH11-022B1A2	820 (32.28)	SH11-082B1A3
270 (10.63)	SH11-027B1A2	920 (36.22)	SH11-092B1A3
320 (12.60)	SH11-032B1A2	1020 (40.16)	SH11-102B1A3
370 (14.57)	SH11-037B1A2	1140 (44.88)	SH11-114B1A3
420 (16.54)	SH11-042B1A2	1240 (48.82)	SH11-124B1A3
470 (18.50)	SH11-047B1A2		
520 (20.47)	SH11-052B1A2		
570 (22.44)	SH11-057B1A2		
620 (24.41)	SH11-062B1A2		

Unit [mm (in)]

**Scale Unit (Resolution: 0.05  $\mu\text{m}$  (0.00000195 in), minimum phase difference: 0.3  $\mu\text{s}$ )**

Measuring length	Model	Measuring length	Model
70 (2.76)	SH11-007B1B2	670 (26.38)	SH11-067B1B3
120 (4.72)	SH11-012B1B2	720 (28.35)	SH11-072B1B3
170 (6.69)	SH11-017B1B2	770 (30.31)	SH11-077B1B3
220 (8.66)	SH11-022B1B2	820 (32.28)	SH11-082B1B3
270 (10.63)	SH11-027B1B2	920 (36.22)	SH11-092B1B3
320 (12.60)	SH11-032B1B2	1020 (40.16)	SH11-102B1B3
370 (14.57)	SH11-037B1B2	1140 (44.88)	SH11-114B1B3
420 (16.54)	SH11-042B1B2	1240 (48.82)	SH11-124B1B3
470 (18.50)	SH11-047B1B2		
520 (20.47)	SH11-052B1B2		
570 (22.44)	SH11-057B1B2		
620 (24.41)	SH11-062B1B2		

Unit [mm (in)]

**Scale Unit (Resolution: 0.1  $\mu\text{m}$  (0.0000039 in), minimum phase difference: 0.16  $\mu\text{s}$ )**

Measuring length	Model	Measuring length	Model
70 (2.76)	SH11-007C1A2	670 (26.38)	SH11-067C1A3
120 (4.72)	SH11-012C1A2	720 (28.35)	SH11-072C1A3
170 (6.69)	SH11-017C1A2	770 (30.31)	SH11-077C1A3
220 (8.66)	SH11-022C1A2	820 (32.28)	SH11-082C1A3
270 (10.63)	SH11-027C1A2	920 (36.22)	SH11-092C1A3
320 (12.60)	SH11-032C1A2	1020 (40.16)	SH11-102C1A3
370 (14.57)	SH11-037C1A2	1140 (44.88)	SH11-114C1A3
420 (16.54)	SH11-042C1A2	1240 (48.82)	SH11-124C1A3
470 (18.50)	SH11-047C1A2		
520 (20.47)	SH11-052C1A2		
570 (22.44)	SH11-057C1A2		
620 (24.41)	SH11-062C1A2		

Unit [mm (in)]

**Scale Unit (Resolution: 0.1  $\mu\text{m}$  (0.0000039 in), minimum phase difference: 0.3  $\mu\text{s}$ )**

Measuring length	Model	Measuring length	Model
70 (2.76)	SH11-007C1B2	670 (26.38)	SH11-067C1B3
120 (4.72)	SH11-012C1B2	720 (28.35)	SH11-072C1B3
170 (6.69)	SH11-017C1B2	770 (30.31)	SH11-077C1B3
220 (8.66)	SH11-022C1B2	820 (32.28)	SH11-082C1B3
270 (10.63)	SH11-027C1B2	920 (36.22)	SH11-092C1B3
320 (12.60)	SH11-032C1B2	1020 (40.16)	SH11-102C1B3
370 (14.57)	SH11-037C1B2	1140 (44.88)	SH11-114C1B3
420 (16.54)	SH11-042C1B2	1240 (48.82)	SH11-124C1B3
470 (18.50)	SH11-047C1B2		
520 (20.47)	SH11-052C1B2		
570 (22.44)	SH11-057C1B2		
620 (24.41)	SH11-062C1B2		

Unit [mm (in)]

---

**Connecting Cable (Connector, Conduit)**

Cable length	Model			
	MR connector	Mini Dsub connector		Frayed tip
	Conduit cable	Conduit cable	No conduit cable	No conduit cable
2 m (78.7 in)	CR1-02MC	—	CR1-02DC	—
3 m (118.1 in)	CR1-03MC	—	CR1-03DC	—
5 m (196.9 in)	CR1-05MC	CR1-05DC	—	CR1-05NN
7 m (275.6 in)	CR1-07MC	CR1-07DC	—	—
10 m (393.7 in)	CR1-10MC	CR1-10DC	—	CR1-10NN
15 m (590.6 in)	CR1-15MC	CR1-15DC	—	—
20 m (787.4 in)	CR1-20MC	CR1-20DC	—	CR1-20NN
30 m (1181.1 in)	CR1-30MC	CR1-30DC	—	CR1-30NN

このマニュアルに記載されている事柄の著作権は当社にあり、説明内容は機器購入者の使用を目的としています。したがって、当社の許可なしに無断で複写したり、説明内容（操作、保守など）と異なる目的で本マニュアルを使用することを禁止します。

The material contained in this manual consists of information that is the property of Sony Manufacturing Systems Corporation and is intended solely for use by the purchasers of the equipment described in this manual.

Sony Manufacturing Systems Corporation expressly prohibits the duplication of any portion of this manual or the use thereof for any purpose other than the operation or maintenance of the equipment described in this manual without the express written permission of Sony Manufacturing Systems Corporation.

Le matériel contenu dans ce manuel consiste en informations qui sont la propriété de Sony Manufacturing Systems Corporation et sont destinées exclusivement à l'usage des acquéreurs de l'équipement décrit dans ce manuel.

Sony Manufacturing Systems Corporation interdit formellement la copie de quelque partie que ce soit de ce manuel ou son emploi pour tout autre but que des opérations ou entretiens de l'équipement à moins d'une permission écrite de Sony Manufacturing Systems Corporation.

Die in dieser Anleitung enthaltenen Informationen sind Eigentum von Sony Manufacturing Systems Corporation und sind ausschließlich für den Gebrauch durch den Käufer der in dieser Anleitung beschriebenen Ausrüstung bestimmt.

Sony Manufacturing Systems Corporation untersagt ausdrücklich die Vervielfältigung jeglicher Teile dieser Anleitung oder den Gebrauch derselben für irgendeinen anderen Zweck als die Bedienung oder Wartung der in dieser Anleitung beschriebenen Ausrüstung ohne ausdrückliche schriftliche Erlaubnis von Sony Manufacturing Systems Corporation.

**Sony Manufacturing Systems Corporation**

**Isehara Plant**

45 Suzukawa, Isehara-shi, Kanagawa 259-1146 Japan

TEL: +81 (463) 92-7971

FAX: +81 (463) 92-7978

**Sony Precision Technology America, Inc.**

20381 Hermana Circle, Lake Forest, CA 92630, U.S.A.

TEL: (949) 770-8400

FAX: (949) 770-8408

**Sony Precision Technology Europe GmbH**

Heinrich-Hertz-Strasse 1 , 70327 Stuttgart, Germany

TEL: (0711) 5858-777

FAX: (0711) 580715

---

<http://www.sonysms.co.jp/>

**Sony Manufacturing Systems Corporation**

1-10 Kiyoku-cho, Kuki-shi, Saitama 346-0035 Japan

SH11 Series  
3-861-878-14

2004.4  
Printed in Japan  
©1997 Sony Manufacturing Systems Corporation